

M90, M100, M110

Technical Reference

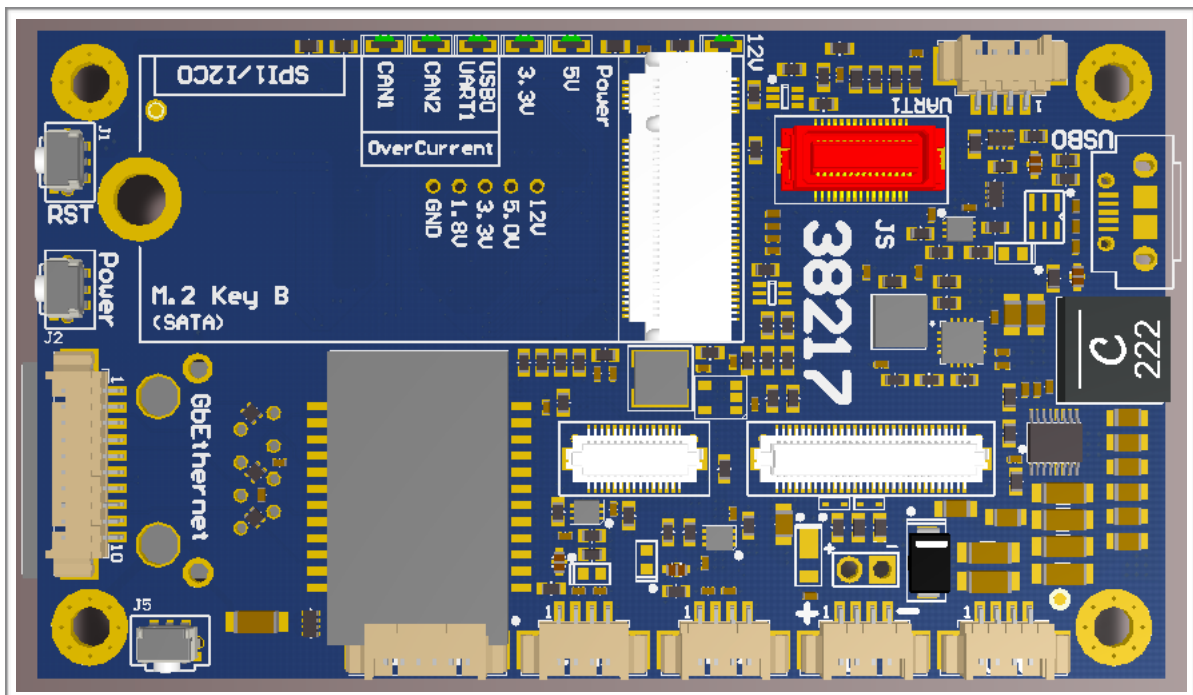

Version 1.2

Preliminary

November 2018

Auvideo GmbH
Kellerberg 3
D-86920 Denkingen
Tel: +49 8243 7714 622
info@auvideo.com
www.auvideo.com

Copyright Notice

Trademarks

NVIDIA, the NVIDIA logo, CUDA, Jetson, Maxwell, Tegra and VisionWorks are registered trademarks and/or trademarks of NVIDIA Corporation in the United States and other countries. Other company and product names may be trademarks of the respective companies with which they are associated.

© Auvideo GmbH 2016

All Rights Reserved

No part of this document or any of its contents may be reproduced, copied, modified or adapted, without the prior written consent of the author, unless otherwise indicated for stand-alone materials.

You may share this document by any of the following means: this PDF file may be distributed freely, as long as no changes or modifications to the document are made.

For any other mode of sharing, please contact the author at the email below. info@auvideo.com

Commercial use and distribution of the contents of this document is not allowed without express and prior written consent of Auvideo GmbH.

Features

M90, M100 and M110

These motherboard are designed to expand the ports of the J100 and J106.

To be completed:

Feature	M90	M100	M110
J100 and J106 compatible	✓	✓	✓
CAN	✓	✓	✓
UART (3.3V level)	-	-	-
UART (RS232 level)	-	-	-
PCIe (4x)	-	-	-
SATA	-	M.2 type B	✓
	-	-	-
	-	-	-
switches: power, reset, force recovery	-	✓/✓/✓	✓/✓/✓
size		50x87mm	50x87mm
power in	7 .. 17V	13.5...42V	13.5 .. 17V

M90

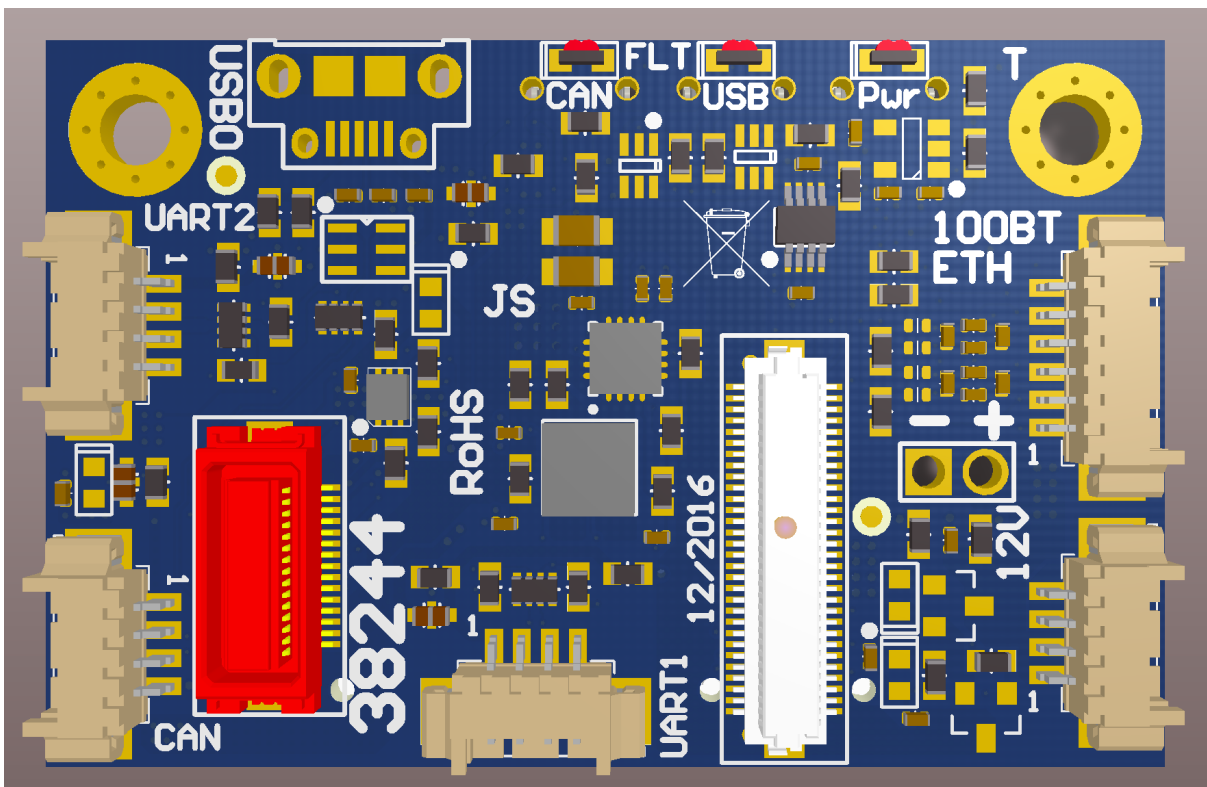
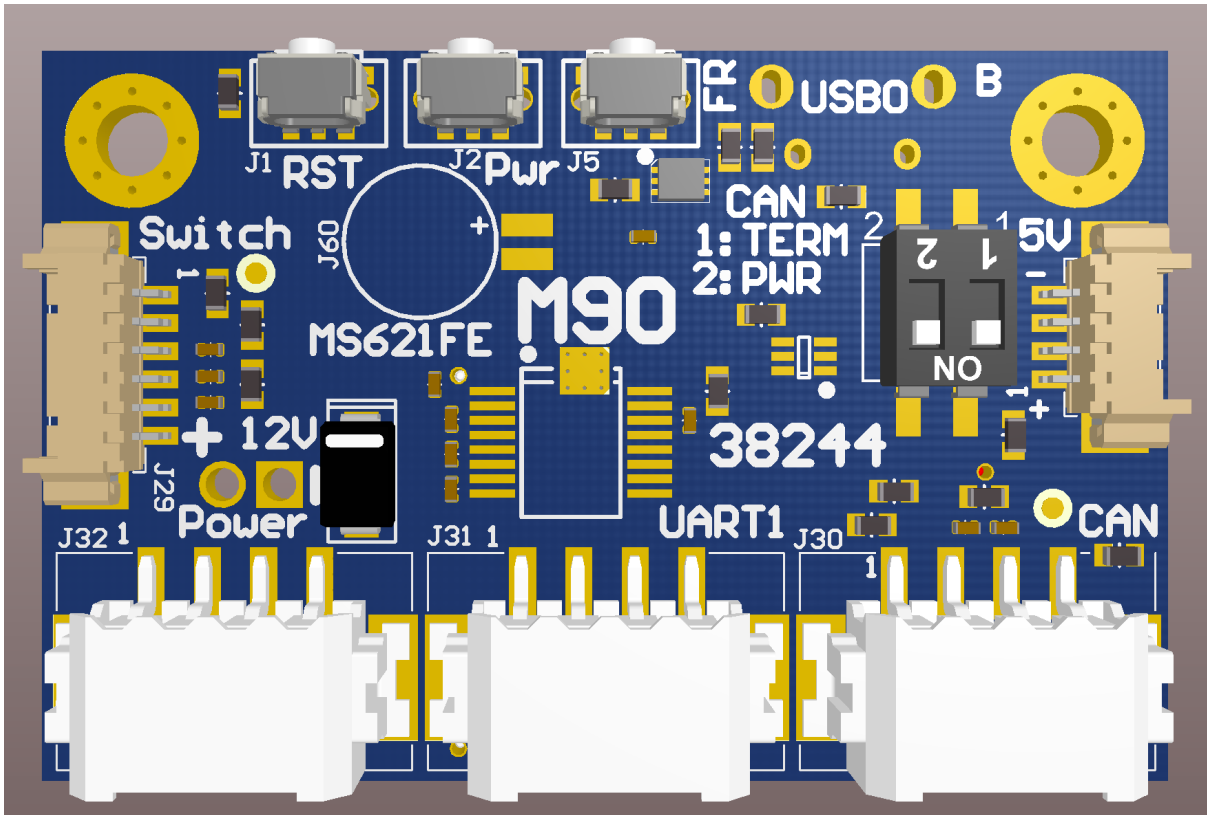

Buttons

Button	Function
J1	Reset
J2	Power up
J5	Force Recovery (for firmware upgrade)

12V Power In (J13, J14 and J32)

These are the 12V power in connectors.

J13: 1.25mm pitch connector (picoblade compatible)

Pin	Function	Jetson TX1	GPIO	Description
1	12V	-	-	12V power in
2	12V	-	-	12V power in
3	GND	-	-	Ground
4	GND	-	-	Ground

J14: 2 holes to solder in a cable

Pin	Function	Jetson TX1	GPIO	Description
1	GND	-	-	Ground
2	12V	-	-	12V power in

J32: Phoenix 1778780

Pin	Function	Jetson TX1	GPIO	Description
1	12V	-	-	12V power in
2	12V	-	-	12V power in
3	GND	-	-	Ground
4	GND	-	-	Ground

UART 1 (J22 and J31)

This is a RS232 level UART 1 port of the TX1/2. The 2 signals are passed through a RS232 level shifter (SN75C3221) and through 33 Ohm series resistors (in a tiny 0804 size resistor array).

Pin	Function	Jetson TX1	GPIO	Description
1	5V	-	-	5V power output (same as USB 2.0 - J17) - max 500mA
2	UART1_TXD	D9	-	UART 1 port (RS232 level): transmit data output
3	UART1_RXD	D10	-	UART 1 port (RS232 level): receive data input
6	GND	-	-	Ground

UART 2 (J15)

This is a TTL level (3.3V) UART 2 port of the TX1/2. The 2 pins are passed through a bi-directional level converter with 3.3V level outputs (TXB0104PWR) and through 33 Ohm series resistors (in a tiny 0804 size resistor array).

Pin	Function	Jetson TX1	GPIO	Description
1	5V	-	-	5V power output (same as USB 2.0 - J17) - max. 500mA
2	UART2_TXD	B16	-	UART 2 port (3.3V TTL level): transmit data output
3	UART2_RXD	B15	-	UART 2 port (3.3V TTL level): receive data input
6	GND	-	-	Ground

USB 2.0 (J17)

USB 2.0 port for firmware upgrades and for USB 2.0 devices like mouse and keyboard.

Pin	Function	Jetson TX1	Description
1	5V	-	5V power controlled by USB0_EN_OC* (A17) - max. 500 mA
2	USB0-D-	B40	USB 2.0 data
3	USB0-D+	B39	USB 2.0 data
4	USB0_ID	A36	floating
5	GND	-	Ground
-	USB0_VBUS	B37	connected to pin 1 of this connector

5V Power out (J23)

This is the 5V power out connector. It is the output of the on-board DC converter which is rated at 3A max. We recommend not to source more than 1A per pin (connector limitation).

Pin	Function	Jetson TX1	GPIO	Description
1	5V	-	-	5V power output (1A max. each)
2	5V	-	-	5V power output (1A max. each)
3	GND	-	-	Ground
4	GND	-	-	Ground

Optional Lithium battery (J60)

Optional MS621FE rechargeable battery to power the RTC of the TX1 or TX2 for extended times.

100BT (100Mbit) Ethernet (J7)

This port is only intended for very short Ethernet connections within a system. It features an RC network (and not magnetics) for isolation. It is designed for small voltage differences between the M90 and the system it is connected to.

Pin	Function	Jetson TX1	RJ45 pin	Description
1	GND	-	-	Ground
2	TX+	-	1	100bT Transmit +
3	TX-	-	2	100bT Transmit -
4	RX+	-	3	100bT Receive +
5	RX-	-	6	100bT Receive -
6	GND	-	-	Ground

Buttons (J29)

This connector may be used to connect external buttons to the M90. Each button should connect to Ground (GND). No pull-up resistor is required or should be used.

Pin	Function	Jetson TX1	GPIO	Description
1	5V	-	-	5V power out (no current limiter- 1A max.)
2	V_RTC	A50	-	RTC battery backup (3V typical)
3	Power	B50	-	Power up
4	Force Recovery	E1	-	Force Recovery
5	Reset	A47	-	Hardware reset of TX1
6	GND	-	-	Ground

CAN (J10 and J30)

This is the optional CAN connector. It is not used with the J100/J106 and the TX1. This option is reserved for the TX2 and J106. The CAN Bus is driven by a TJA1051TK/3,118 CAN bus transceiver. It translates CAN0_TX and CAN0_RX to CAN_H and CAN_L.

Pin	Function	Jetson TX2	Pin	Description
1	5V	-	-	5V power out (controlled by J4 switch 2)
2	CAN_H	CAN0_TX	D19	CAN data high (2.5V nominal voltage)
3	CAN_L	CAN0_RX	D18	CAN data low (2.5V nominal voltage)
4	GND	-	-	Ground

CAN switches (J4)

Switch	Function	Description
1	CAN Termination	On: 120 Ohm CAN bus termination active Off: no CAN bus termination
2	CAN Power	On: Power pin 1 of J10/J30 with 5V 500mA Off: no power

M100

M100

The M100 is a compact port extender for the J100 and J106. It has the same size as the TX1 and TX2 and brings out multiple additional interfaces.

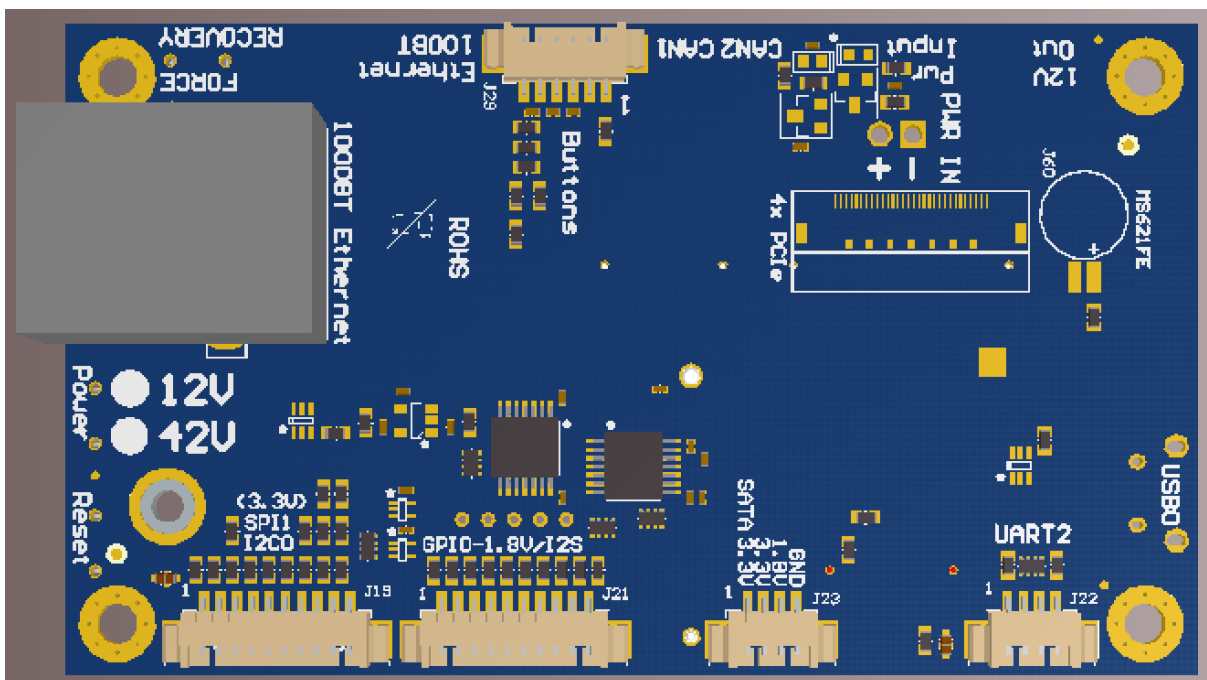
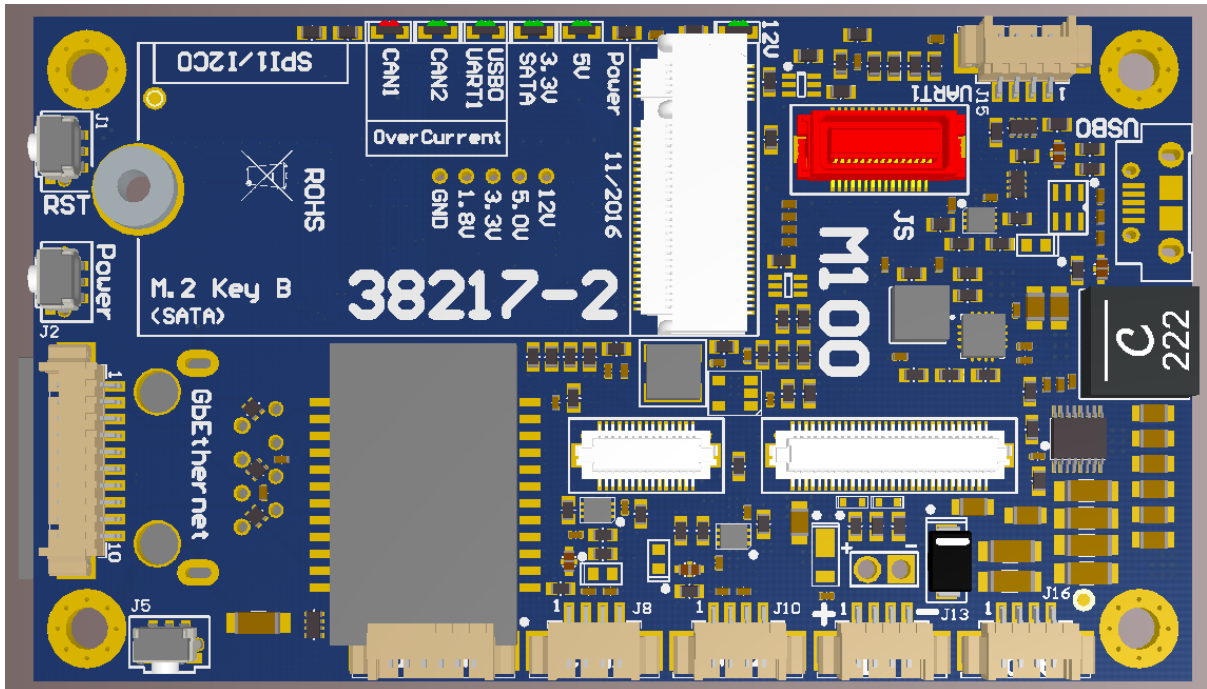

Outputs (GPIOs, I2S, SPI) on the M100

The M100 converts the 1.8V level output signals to 3.3V. It uses a bidirectional level converter, which automatically detects the direction of the signal. For the level conversion to work properly, caution must be taken, if there is a pull-up resistor on any output. This applies to all outputs including GPIOs and special function outputs like SPI, I2S. If there are any pull-up resistors on these outputs, they must have more than 50 kOhm. If there is a pull-up resistor with a lower value, than the level converter may determine that the signal is driven from the outside, and that this pin should be treated as input.

LEDs

LED	Description
12V	input power LED
5V	on-board 5V 3A DC converter is powered up (J100/J106 required)
3.3V SATA	on-board 3.3V 3A DC converter is powered up (J100/J106 required)
USB/UART1	over current on the 5V supply of the USB2 or UART1 port
CAN2	over current on the 5V supply of the CAN2 port
CAN1	over current on the 5V supply of the CAN1 port

The 12V power LED will light up as soon as the power is connected to the M100, independent of whether a J100/J106 is plugged in. The 2 on-board DC converters only power up if a J100 or J106 is plugged in.

Buttons

Button	Function
J1	Reset
J2	Power up
J5	Force Recovery (for firmware upgrade)

UART 1 (J7)

This is a TTL level (3.3V) UART port of the TX1/2. The 2 pins are passed through a bi-directional level converter with 3.3V level outputs (TXB0104PWR) and through 33 Ohm series resistors (in a tiny 0804 size resistor array).

Pin	Function	Jetson TX1	GPIO	Description
1	5V	-	-	5V power output (same as USB 2.0 - J17)
2	UART1_TXD	D9	-	UART 1 port (3.3V TTL level): transmit data output
3	UART1_RXD	D10	-	UART 1 port (3.3V TTL level): receive data input
6	GND	-	-	Ground

USB 2.0 (J17)

USB 2.0 port for firmware upgrades and for USB 2.0 devices like mouse and keyboard.

Pin	Function	Jetson TX1	Description
1	5V	-	5V power controlled by USB0_EN_OC* (A17) - max. 500 mA
2	USB0-D-	B40	USB 2.0 data
3	USB0-D+	B39	USB 2.0 data
4	USB0_ID	A36	floating
5	GND	-	Ground
-	USB0_VBUS	B37	connected to pin 1 of this connector

12V Power out (J16)

This is the 12V power out connector. It is the output of the on-board DC converter. The M100-12 has no on-board 12V DC converter. Here the 12V power in and out connectors are connected together.

Pin	Function	Jetson TX1	GPIO	Description
1	12V	-	-	12V power output (1A max.)
2	12V	-	-	12V power output (1A max.)
3	GND	-	-	Ground
4	GND	-	-	Ground

Power input (J13)

This is the power input connector. The standard version is the M100-42. It features an on-board DC down (buck) converter which supports an input voltage of 13.5V to 42V. If the input voltage is less than 13.5V the 12V output voltage may not be stable and it will track the input voltage. For most use cases this actually may be ok, as the Jetson TX1 can operate with a supply voltage down to 7V. The same is true for the DC converters on the M100 and J100/J106.

The M100-12 is a special low cost version of the M100. Here the 13.5V to 42V in DC down converter is not populated and the power in and 12V power out rail are shorted together. For this special version the voltage input range is 7V to 17V. Please note that the J16 power our connector directly supplies the input voltage.

Alternatively power may be provided via the two 1.5mm holes, where cables may be soldered in.

Pin	Function	Jetson TX1	GPIO	Description
1	power in	-	-	M100-12: 12V power input (range: 7V to 17V) M100-42: 13.5 to 42V
2	power in	-	-	M100-12: 12V power input (range: 7V to 17V) M100-42: 13.5 to 42V
3	GND	-	-	Ground
4	GND	-	-	Ground

CAN 2 (J10)

This is the CAN connector which is connected to the SPI to CAN controller on the J100 or J106. The CAN Bus is driven by a TJA1051TK/3,118 CAN bus transceiver.

Pin	Function	Jetson TX1	GPIO	Description
1	5V	-	-	5V power out
2	CAN_H	-	-	CAN data high (2.5V nominal voltage)
3	CAN_L	-	-	CAN data low (2.5V nominal voltage)
4	GND	-	-	Ground

CAN1 (J8)

This is an optional CAN connector. It is not used with the J100/J106 and the TX1. This option is reserved for the TX2 and J106. The CAN Bus is driven by a TJA1051TK/3,118 CAN bus transceiver. It translates CAN0_TX and CAN0_RX to CAN_H and CAN_L.

Pin	Function	Jetson TX2	Pin	Description
1	5V	-	-	5V power out
2	CAN_H	CAN0_TX	D19	CAN data high (2.5V nominal voltage)
3	CAN_L	CAN0_RX	D18	CAN data low (2.5V nominal voltage)
4	GND	-	-	Ground

100BT (100Mbit) Ethernet (J7)

This connector is only populated on the M100-MP. This port is only intended for very short Ethernet connection within a system. It features an RC network (and not magnetics) for isolation. It is designed for small voltage differences between the M100 and the system it is connected to.

Pin	Function	Jetson TX1	RJ45 pin	Description
1	GND	-	-	Ground
2	TX+	-	1	Transmit +
3	TX-	-	2	Transmit -
4	RX+	-	3	Receive +
5	RX-	-	6	Receive -
6	GND	-	-	Ground

GbE (Gigabit Ethernet) (J3)

This connector is populated on the M100-GP and M100-GR. This port offers the full Ethernet range as it is equipped with GbE magnetics.

Pin	Function	Jetson TX1	RJ45 pin	Description
1	GND	-	-	Ground
2	GBE_MDIO_P	E48	1	Data 0 + (Transmit +)
3	GBE_MDIO_N	E49	2	Data 0 - (Transmit -)
4	GBE_MD11_P	F47	3	Data 1 + (Receive +)

Pin	Function	Jetson TX1	RJ45 pin	Description
5	GBE_MDI1_N	F48	6	Data 1- (Receive -)
6	GBE_MDI2_P	G48	4	Data 2 +
7	GBE_MDI2_N	G49	5	Data 2 -
8	GBE_MDI3_P	H47	7	Data 3 +
9	GBE_MDI3_N	H48	8	Data 3 -
10	GND	-	-	Ground

GbE (Gigabit Ethernet RJ45) (J18)

This Ethernet RJ45 connector is populated only on the M100-GR. On the M100-GP is may optionally be populated with a Steward SS-6488S-A-NF connector.

Buttons (J29)

This connector may be used to connect external buttons to the M100. Each button should connect to Ground (GND). No pull-up resistor is required or should be used.

Pin	Function	Jetson TX1	GPIO	Description
1	5V	-	-	5V power out (no current limiter- 1A max.)
2	V_RTC	A50	-	RTC battery backup (3V typical)
3	Power	B50	-	Power up
4	Force Recovery	E1	-	Force Recovery
5	Reset	A47	-	Hardware reset of TX1
6	GND	-	-	Ground

UART 2 (J22)

This is a TTL level (3.3V) UART 2 port of the TX1 and TX2. The 2 pins are passed through a bi-directional level converter with 3.3V level outputs (TXB0104PWR) and through 33 Ohm series resistors (in a tiny 0804 size resistor array).

Pin	Function	Jetson TX1	GPIO	Description
1	5V	-	-	5V power output (same as USB 2.0 - J17)
2	UART2_TXD	B16	-	UART 2 port (3.3V TTL level): transmit data output
3	UART2_RXD	B15	-	UART 2 port (3.3V TTL level): receive data input
6	GND	-	-	Ground

Power out (J23)

This is the general purpose power out connector to power external devices.

Pin	Function	Jetson TX1	GPIO	Description
1	3.3V SATA	-	-	output of the 3.3V 3A on-board DC converter
2	3.3V	-	-	3.3V provided by the J100 or J106
3	1.8V	-	-	1.8V provided by the J100 or J106 (max. 50mA)
4	GND	-	-	Ground

I2S and GPIO (J21)

I2S (digital audio in and out - 2 channels) and GPIO signals (1.8V). Please check the `gpio_names.h` file to translate the GPIO names into the 3 digit numbers for command line GPIO control.

Pin	Function	Jetson TX1	GPIO TX1	Description
1	I2S1_SOUT	D14	-	I2S1 digital audio: data out (3.3V level)
2	I2S1_CLK	C15	-	I2S1 digital audio: bit clock (3.3V level)
3	I2S1_LRCLK	D13	-	I2S1 digital audio: word clock (3.3V level)
4	I2S1_SIN	C14	-	I2S1 digital audio: data in (3.3V level)
5	WIFI2_WAKE	B20	GPIO3_PI.01	GPIO10_WIFI_WAKE_AP (1.8V level - unbuffered)
6	BT2_EN	B21	GPIO3_PI.02	GPIO12_BT2_EN (1.8V level - unbuffered)
7	GNSS_PPS	B18	-	GNSS_PPS (1.8V level - unbuffered)
8	AP_WAKE_BT	B19	GPIO3_PH.07	GPIO11_AP_WAKE_BT (1.8V level - unbuffered)
9	WIFI_EN	A29	GPIO3_PI.00	SDIO_RST (1.8V level - unbuffered)
10	GND	-	-	Ground

SPI and GPIO (J21)

I2S (digital audio in and out - 2 channels) and GPIO signals (1.8V). Please check the `gpio_names.h` file to translate the GPIO names into the 3 digit numbers for command line GPIO control.

Pin	Function	Jetson TX1	GPIO TX1	Description
1	5V	-	-	5V power out (no current limiter- 1A max.)
2	SPI2_CLK	H14	-	SPI 2 clock output (3.3V level)
3	SPI2_MISO	H15	-	SPI 2 MISO input (3.3V level)
4	SPI2_MOSI	G15	-	SPI 2 MOSI output (3.3V level)
5	SPI2_CS0	G16	-	SPI 2 CS0 output (3.3V level)
6	SPI2_CS1	F16	-	SPI 2 CS1 output (3.3V level)

Pin	Function	Jetson TX1	GPIO TX1	Description
7	INT_SPI2	A23	GPIO3_PL.01	GPIO_EXP0_INT
8	I2C0_CLK	E15	-	I2C 0 clock (device 0)
9	I2C0_DAT	D15	-	I2C 0 data (device 0)
10	GND	-	-	Ground

RTC battery (J60)

Optionally a rechargeable battery may be added to the M100. The recommended type is MS621FE.

SATA M.2 type B slot (J4)

This slot is designed for SATA cards with 2242 form factor. Please use an M3 screw with flat head to fix the M.2 card.

M110

1. to be added

FAQ

1. to be added

Disclaimer

Thank you for reading this manual. If you have found any typos or errors in this document, please let us know.

This is the preliminary version of this data sheet. Please treat all specifications with caution as there may be any typos or errors.

The Auvideo Team